

HL-46H 6 TON 4 POST HOIST

Heshbon HL-46H 6 Tonne 4 Post Hoist.

FEATURES

- Hydraulic cylinder located in the fixed platform and is perfectly protected
- High resistant galvanised and pre-stretched lifting cable
- Lock release lever for emergency situations.
- Adjustable parking ratchet rails ensure the platform and cross members horizontal within 4 wheel alignment tolerances.
- Automatic spring loaded eccentric brake system in event of cable breakage and ensures complete stability during parking.
- Self lubricated large diameter pulleys and maintenance-free brushes.

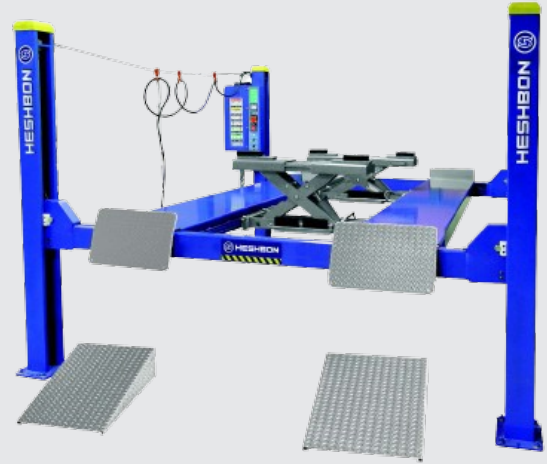

CONCRETE

150mm thick, reinforced, free from cracks/seams, 30mpa & cured 28+ days

SPECIFICATIONS

Model No.	HL-46H
Lifting Capacity (kg)	Body: 6,000kg / Jack: 3,000kg
Max. Lifting Height (mm)	Body: 1,750 / Jack: 595mm
Min. Lifting Height (mm)	184mm
Power Supply & Motor	3ph: 3HP, 4P, 220V/380V, 50/60Hz

LAYOUT

